

(No Model.)

3 Sheets—Sheet 1.

E. LESLIE.

ROTARY EXCAVATOR FOR REMOVING SNOW.

No. 391,903.

Patented Oct. 30, 1888.

Fig. 1.

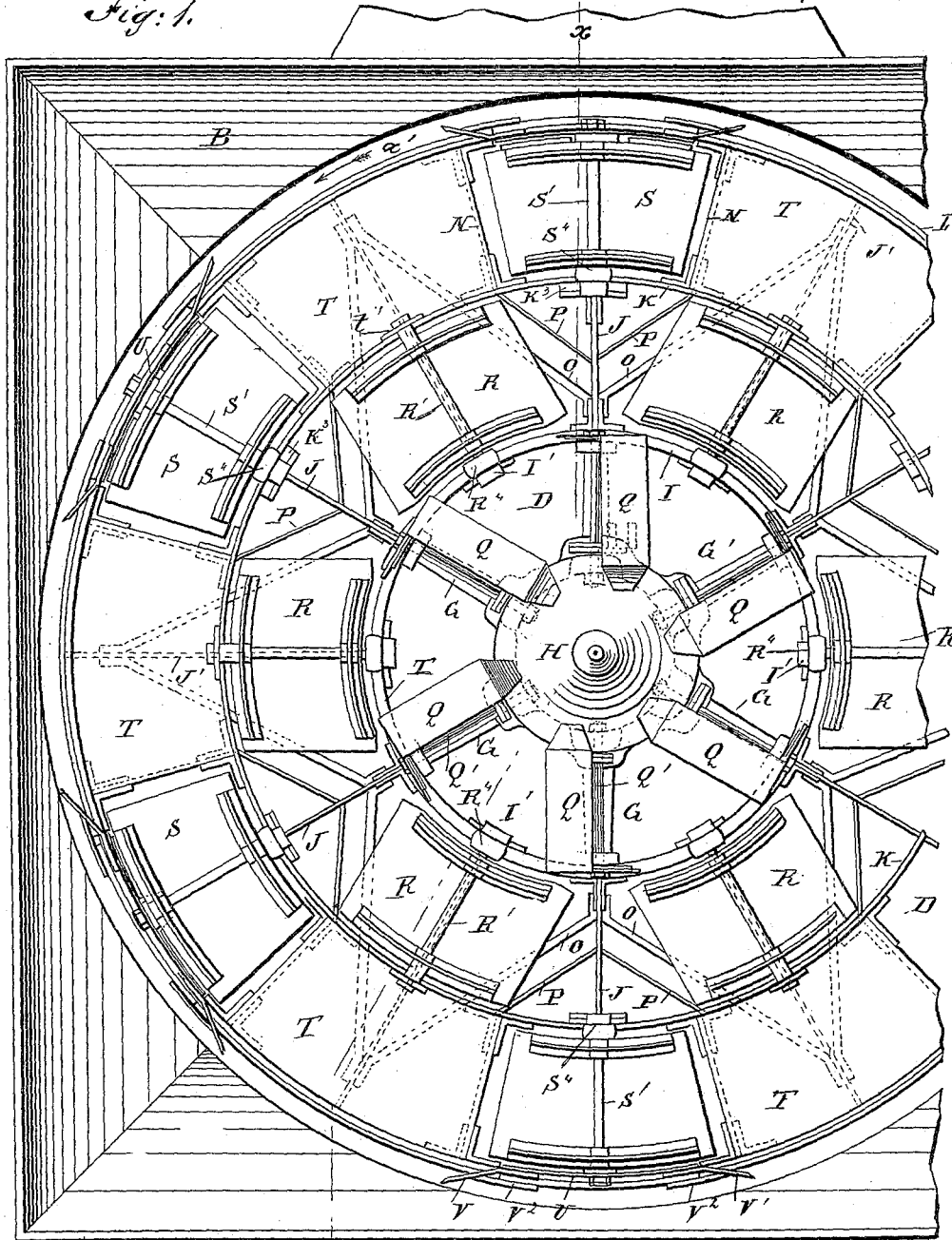

WITNESSES:

Chas. Nida
Wm. Sedgwick

INVENTOR,

E. Leslie
 BY *Munn & Co*

ATTORNEY.

(No Model.)

3 Sheets—Sheet 2.

E. LESLIE.

ROTARY EXCAVATOR FOR REMOVING SNOW.

No. 391,903.

Patented Oct. 30, 1888.

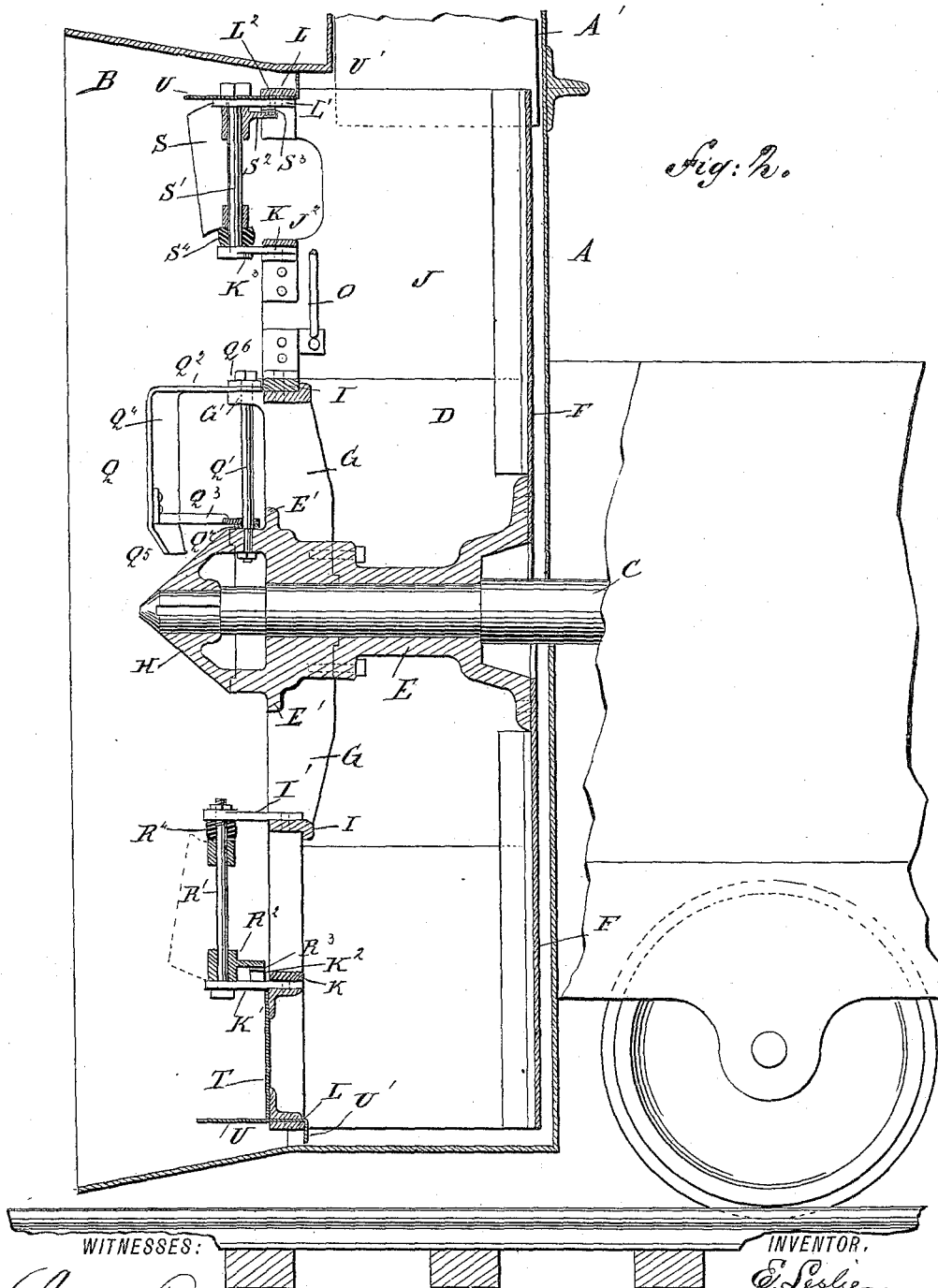

Fig. 10.

WITNESSES:

Cros. Nida.
C. Sedgwick.

INVENTOR.

E. Leslie.
Munn & Co.

BY

ATTORNEY.

(No Model.)

3 Sheets—Sheet 3.

E. LESLIE.

ROTARY EXCAVATOR FOR REMOVING SNOW.

No. 391,903.

Patented Oct. 30, 1888.

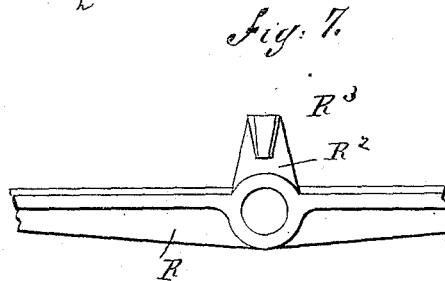
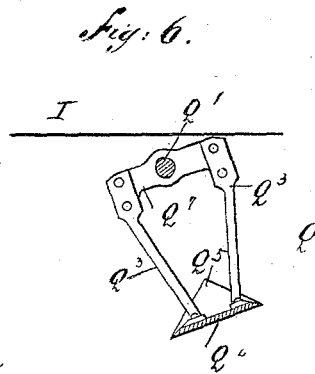
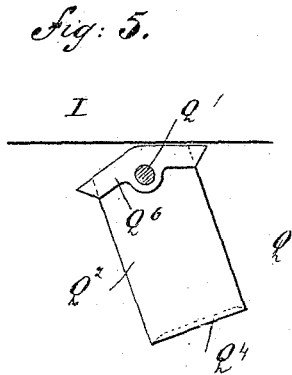
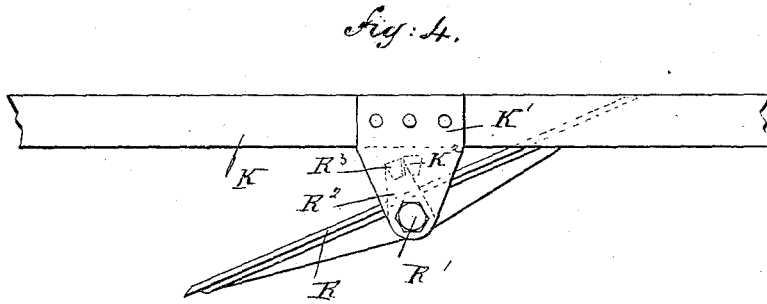
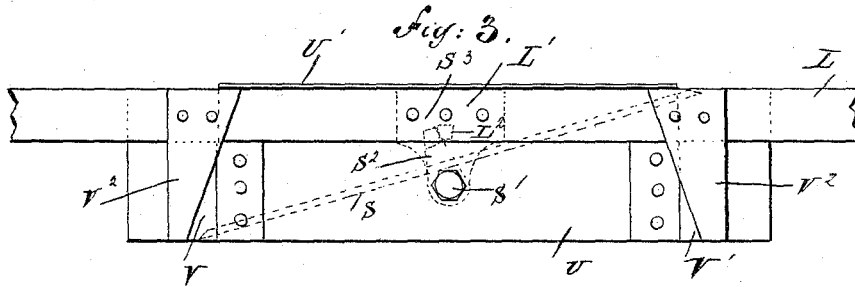

WITNESSES:

Chas. Nida
Co. Sedgwick.

INVENTOR

E. Leslie

BY

Munn & Co.

ATTORNEY.

UNITED STATES PATENT OFFICE.

EDWARD LESLIE, OF ORANGEVILLE, ONTARIO, CANADA.

ROTARY EXCAVATOR FOR REMOVING SNOW.

SPECIFICATION forming part of Letters Patent No. 391,903, dated October 30, 1888.

Application filed April 11, 1883. Serial No. 270,347. (No model.)

To all whom it may concern:

Be it known that I, EDWARD LESLIE, of Orangeville, in the county of Dufferin, Province of Ontario, and Dominion of Canada, have invented a new and Improved Rotary Excavator for Removing Snow, of which the following is a full, clear, and exact description.

The invention relates to a rotary excavator for removing snow, for which United States Letters Patent No. 380,809, dated April 10, 1888, were granted to me.

The object of the present invention is to provide a new and improved excavator which very effectually and rapidly removes the snow from the track, prevents the clogging of the working parts, and automatically locks the reversing knives in position.

The invention consists of certain parts and details and combinations of the same, as will be fully described hereinafter, and then pointed out in the claims.

Reference is to be had to the accompanying drawings, forming a part of this specification, in which similar letters of reference indicate corresponding parts in all the figures.

Figure 1 is a front elevation of the improvement. Fig. 2 is a sectional side elevation of the same on the line *xx* of Fig. 1. Fig. 3 is an enlarged plan view of part of the outer ring. Fig. 4 is an enlarged plan view of one of the reversible middle knives. Fig. 5 is an enlarged plan view of one of the inner knives. Fig. 6 is a sectional plan view of the same, and Fig. 7 is an enlarged inverted plan view of part of one of the middle knives.

The improved excavator is preferably mounted on a car supporting at its front end the stationary casing A, provided on its front with a square hood, B, similar in shape and form to the hood referred to in the patent above mentioned. On the car is mounted to rotate the horizontal shaft C, extending centrally through the casing A and carrying on its outer end a wheel, D, rotating in the casing A. The wheel D is provided with a hub, E, fastened on the said shaft C, and on the inner end of the hub is secured the circular plate F, placed near the inner wall of the casing A without touching the same.

The hub E is preferably made in two parts bolted together, as shown in Fig. 2, and on

the outer end of the hub is held a cone, H, extending a suitable distance into the flaring hood B. From the front part of the hub E extend the spokes G, on the outer end of which is secured a ring, I, from which extend the radial wings or fans J in line with the spokes G, before mentioned. Wings or fans J', similar to the wings J, extend radially from the said ring I, but are located midway between the said wings J. The wings J and J' extend to the inner plate, F, to which they are also secured.

The wings J and J' are provided with recesses or slots J², located at their front edges, at about the middle, and in these recesses is secured the ring K, held concentrically with the ring I. The front top ends of the wings or fans J and J' are covered by a ring, L, secured to the wings in any suitable manner and arranged concentric with the rings K and I. The rings K and L are also connected with each other by radial braces N, located between two successive wings, J and J', and diagonal braces O extend from the lower ends of the wings J to the upper ends of the wings J' on each side of the respective wings J, and the braces P extend from the said wings J to the ring K, as is plainly shown in Fig. 1.

On the outer end and in front of each spoke G is formed a lug, G', through which passes the radial shaft or rod Q', extending inward and being fastened on the outer end of the hub E, as is plainly shown in Fig. 2. On each shaft or rod Q' is held to swing a knife, Q, consisting of the arms Q¹ and Q², pivoted on the said rod Q' and supporting the knife-blade Q³, slightly bent inward at its lower end, Q³, toward the cone H. The pivoted ends of the upper arms, Q², each carry an angular piece, Q⁴, adapted to rest with its inner edges alternately against the edge of the ring I, as is plainly shown in Fig. 5, and the ends of the pivoted end pieces, Q⁴, of the lower arms, Q¹, extend in line with the face of the knife-blade Q³ and a short distance to each side of the shaft or rod Q'. The ends of the pieces Q⁴ are adapted to rest alternately on a projection, E', formed on the hub E, as illustrated in Figs. 2 and 6.

When the wheel D rotates in one direction, then one arm of the angular piece Q⁴ and the corresponding end of the piece Q³ rest, respect-

ively, on the ring I and the projection I' at one side of the shaft Q', and when the wheel D is turned in the opposite direction the other arm of the angular piece Q⁶ and the corresponding end of the piece Q' rest on the ring I and the projection E', respectively, at the other side of the shaft Q'. The knife-blade Q' stands in either case inclined to the face of the wheel D, as illustrated in Figs. 1, 2, 5, and 6.

Between the rings I and K are placed the reversible knives R of a number equal to the knives Q, and located between two successive knives Q, but a little nearer to the face of the wheel. Each knife R is preferably made rectangular in shape, with sharpened side edges. On the rings I and K are secured the outwardly-extending brackets I' and K', on two corresponding ones of which is held a shaft or rod, R', in line with the radial wings or fans J'. On each shaft or rod R' is held to swing one of the knives R, provided on its upper end with an arm, R², extending inwardly and at right angles to the knives R, and having a lug, R³, adapted to rest against a lug, K², formed on the under side of the bracket K', (see Fig. 4,) so as to hold the knife R in an angular position in relation to the face of the wheel D. On the inner end of the shaft R' is held a spring, R⁴, which presses the knife R outward on the shaft R', so that the lug R³ is pressed firmly against the under side of the bracket K'.

When the wheel D rotates in one direction, the lug R³ rests against one side of the lug K², and when the motion of the wheel is reversed then the lug R³ passes over the lug K², the compression of the spring R⁴ permitting a slight inward sliding movement of the knife R on its shaft R', and the lug R³ then rests against the other side of the stationary lug K². The centrifugal force of the rotating wheel D causes the knife R to press outward, so that the arm R² presses against the under side of the bracket K', whereby the lug R³ is held firmly in place on either side of the fixed lug K², aided by the spring R⁴. The knife R is thus held in an angular position in relation to the face of the wheel D. At the moment that the wheel D is reversed the centrifugal force is zero, and the spring is sufficiently compressed by the knife coming in contact with the snow to permit the lug R³ to pass over the lug K² to the other side of the latter. The centrifugal force of the wheel D and the spring R⁴ holds the knife R in this reversed position in the same manner as above described.

On the rings K and L, and in front of the wings J, are secured the outwardly-extending brackets K³ and L', on two corresponding ones of which is held the shaft or rod S', arranged radially and in line with the respective wing J. On each rod S' is held to swing a knife, S, similar in shape and form to the knife R, above described. The shaft or rod S' is, however, set farther inward toward the face of the wheel D, so that the three sets of knives Q, R, and S are above and in front of each other, as is

plainly shown in Fig. 2. The knife S is also provided on its upper end with an arm, S², extending inward and carrying a lug, S³, adapted to rest on the sides of a lug, L², held on the under side of the bracket L', and a spring, S⁴, is fastened on the shaft or rod S' and presses the knife outward on the shaft S'. This arrangement is the same as above described in reference to the knife R and serves the same purpose—that is, to permit an automatic reversing of the knife and to lock it in place after being reversed.

It will be seen that the knives S are the same in number as the knives R and Q, and are located in line with the latter and between the knives R. The space between the rings Q and L and two successive knives S is covered by a plate, T, held on the front of the said rings K and L and secured to the latter and to the braces N in any suitable manner.

To the outer side of the ring L, above each knife S, is secured a segmental plate, U, which projects outward to the outer edge of the knife S, as illustrated in Figs. 2 and 3. The inner end, U', of the segmental plate U is turned upward at right angles and extends to within a short distance of the hood B. The front end of the segmental plate U forms a protection for the top edge of the knife S, and the turned-up end U' forms a packing for the wheel D and the hood B, so as to prevent the snow from clogging between the hood and the radial wings J.

On the ends of the segmental plate U are secured, by rivets or other means, the upwardly and outwardly inclined cutters V and V', respectively, the outer cutting-edges of which extend to within a short distance of the hood B. A strengthening-plate, V², is secured to the top of the ring L and extends outward over the inclined plate V or V', respectively, to prevent the latter from being broken. The cutters V and V' serve to cut up the snow in the hood B, so that all clogging of the wheel D is prevented. The casing A is provided with the usual spout, A', which serves to lead the snow to one side of the railroad-track.

The operation is as follows: When the shaft C is rotated in the direction of the arrow a', then the three sets of knives Q, R, and S are opened in the direction of the rotation of the wheel, and the knives R and S are additionally locked in place by the lugs R³ S³ respectively engaging the lugs K² L², as above described. The snow thus passes into the openings formed by the respective knives in the front of the wheel D, and the snow in the center of the hood D is pushed by the cone H upward and into the opening formed by the innermost set of knives, Q. The snow, after entering the wheel D, is forced out of the same by the wings or fans J into the spout A', which leads the snow to one side of the track. The snow cut by the knives Q passes to the inside of the wheel D between the ring I and the hub E, and does not come in contact, on its outward movement caused by the wings J, with

the snow from the knives R, as the latter are located alternately with the said knives Q and above the latter and nearer to the rim of the wheel D. The snow cut by the knives Q is thrown against the lower part of the wings J, while the snow cut by the knives R passes onto the wings J'. The snow cut by the knives R also does not come in contact with the snow cut by the knives S, as the latter are located alternately between the knives R above the same and nearer to the rim of the wheel D. The snow from the knives S passes to the wings J, while the snow from the knives R passes directly onto the wings J'. Thus the several sets of knives cut the snow in the hood B independently of each other and deliver it to the wings or fans J and J' without crowding or clogging the same, so that the wheel D revolves freely and very easily, requiring less motive power for revolving it.

It will be seen that the various braces strengthen the wheel materially, so that the latter is not very liable to be broken or to get out of order.

When the machine commences to operate, then the inner knives, Q, come first in contact with the snow, thus making the first cut, which is the hardest and over which the engine has the most power. The first cut makes a hole in the center of the snow, thereby permitting the snow in the hood B to compress toward the center, making it easier for the other sets of knives, R and S, to cut, and the machine is more easily moved forward into the snow. The inner knives, Q, may be extended outward to the front end of the square hood B.

Having thus described my invention, what I claim as new, and desire to secure by Letters Patent, is—

1. In a rotary excavator, a revolving wheel provided with radial wings or fans and sets of knives held on the front of the said wheels and located one in front of the other, substantially as shown and described.

2. In a rotary excavator, a revolving wheel provided with radial wings or fans and sets of knives held on the said wheel and arranged one above the other and one in front of the other, substantially as shown and described.

3. In a rotary excavator, the combination, with a revolving wheel provided with a central cone at its front and radial wings or fans, of sets of knives arranged one above the other and arranged alternately, substantially as shown and described.

4. In a rotary excavator, the combination, with a revolving wheel provided with a central cone held at its front end, of radial wings or fans held on the said wheel, sets of reversible knives held on the front of the said wheel and located one above the other and one in front of the other, substantially as shown and described.

5. In a rotary excavator, the combination, with a revolving wheel, of radial fans held on the said wheel and three sets of self-revers-

ing knives held in front of the said wheel and arranged alternately and one above the other and one in front of the other, substantially as shown and described.

6. In a rotary excavator, the combination, with a wheel having radial wings or fans, of self-reversing knives held on the front of the said wheel and locked automatically in place, substantially as shown and described.

7. In a rotary excavator, the combination, with a wheel having radial wings or fans, of self-reversing knives held on the front of the said wheel, and means, substantially as described, for automatically locking the said knives in place, as set forth.

8. In a rotary excavator, the combination, with a revolving wheel provided with radial wings or fans and a cone in its center in front, of an inner set of knives held in front of the said wheel, a middle set of knives held on the front of the said wheel, the several knives of this set being placed alternately with the several knives of the said inner set of knives, and an outer set of knives, also held on the front of the said wheel, and having its several knives located alternately with the several knives of the said middle set of knives, substantially as shown and described.

9. In a rotary excavator, the combination, with a revolving wheel provided with radial wings or fans and a cone in its center in front, of an inner set of knives held in front of the said wheel, a middle set of knives held on the front of the said wheel, the several knives of this set being placed alternately with the several knives of the said inner set of knives, and an outer set of knives, also held on the front of the said wheel, and having its several knives located alternately with the several knives of the said middle set of knives, the said several sets of knives being placed one in front of the other, substantially as shown and described.

10. In a rotary excavator, the combination, with a revolving wheel provided with radial wings or fans and a cone in its center in front, of an inner set of knives held in front of the said wheel, a middle set of knives held on the front of the said wheel, the several knives of this set being placed alternately with the several knives of the said inner set of knives, and an outer set of knives, also held on the front of the said wheel, and having its several knives located alternately with the several knives of the said middle set of knives, and covering-plates held on the said wheel between the successive knives of the outer set of knives, substantially as shown and described.

11. In a rotary excavator, the combination, with a revolving wheel provided with radial wings or fans and a cone in its center in front, of an inner set of knives held in front of the said wheel, a middle set of knives held on the front of the said wheel, the several knives of this set being placed alternately with the several knives of the said inner set of knives, and an outer set of knives, also held on the front

of the said wheel, and having its several knives located alternately with the several knives of the said middle set of knives, the said several sets of knives being reversible and adapted to lock themselves automatically in place on the said wheel, substantially as shown and described.

12. In an excavator, the combination, with a stationary hood, of a revolving wheel provided with sets of knives and cutters held on the rim of the said wheel and extending horizontally outward and upward toward the said hood to direct the snow to the said knives, substantially as shown and described.

13. In an excavator, the combination, with a hood, of a revolving wheel provided with sets of knives and radial wings or fans, and inclined cutters held on the periphery of the said wheel and extending outward toward the said hood in front of the said wheel to direct the snow to the said knives, substantially as shown and described.

14. In an excavator, the combination, with a hood and a casing supporting the said hood, of a wheel held to revolve in the said casing and provided with radial wings or fans, sets of self-reversing knives held in front of the said wheel in the said hood, and inclined cutters held on the periphery of the said wheel and extending outward toward the said hood in front of the wheel to direct the snow to the said knives, substantially as shown and described.

15. In an excavator, the combination, with a fixed casing and a hood supported in the same, of a wheel held to rotate in the said casing and provided with sets of reversing-knives and segmental plates held on the said wheel, and having an upwardly-turned inner edge extending toward the said hood to prevent the snow from passing from the fans to the front of the wheel, substantially as shown and described.

16. In an excavator, the combination, with a revolving wheel, of knives held to swing on the front of the said wheel, an arm extending from the said knives and provided with a lug, and a fixed lug held on the said wheel and engaged by the lug on the said arm, substantially as shown and described.

17. In an excavator, the combination, with a revolving wheel, of knives held to swing on the front of the said wheel, an arm extending from the said knives and provided with a lug, a fixed lug held on the said wheel and engaged by the lug on the said arm, and a spring pressing against the said knife to hold the lug of its arm in contact with the said lug on the said wheel, and also permitting the said arm to pass with its lug over the fixed lug when the wheel is reversed, substantially as shown and described.

EDWARD LESLIE.

Witnesses:

THEO. G. HOSTER,
C. SEDGWICK.